



FASTEST ALIGNMENT EVER

EASY GLASS® PRIME
ALIGN STRAIGHTAWAY



EASY GLASS® PRIME



ALIGNING GLASS IN A BALUSTRADE HAS NEVER BEEN SO EASY AND SECURE

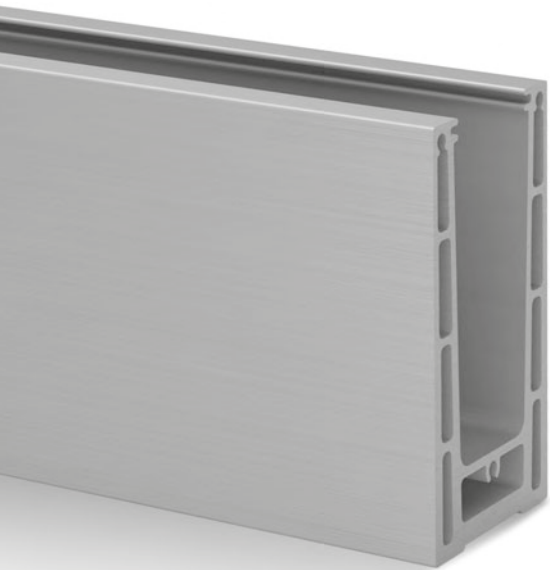

Easy Glass® Prime is Q-railing's latest glass railing system, and as the name already implies, the absolute number one in glass alignment! Its BS 6180 certified base shoe includes the revolutionary adjustable Q-disc® System, which makes adjusting and securing glass infills easier than ever before.

Mounting the top mount* base shoe itself is simple as well. Thanks to tolerances of the drilled holes, you can tighten bolts and level uneven surfaces effortlessly. Plus, you can carry out all the work from the inner side of the balustrade. No need for any scaffolding!



Inlay with sliding system for alignment



Q-disc

Rubber set

* Fascia mount base shoe available as from January 2019.

Revolutionary Q-disc® System for the fastest alignment ever



It is the adjustable Q-disc System that really sets Easy Glass Prime apart. This extended version of the world-changing 2018 Q-disc System allows for super fast and easy glass alignment!

THE BENEFITS

- Choose from various base shoe fixing methods, even threaded rods
- Incredibly simple and secure glass mounting and alignment thanks to the adjustable Q-disc System
- A simple click ensures you of secure glass fixation
- For glass thickness of 21.52 mm
- Symmetrical top-mount base shoe, it is always positioned correctly
- BS 6180 certified to resist line loads of up to 1.5 kN/m

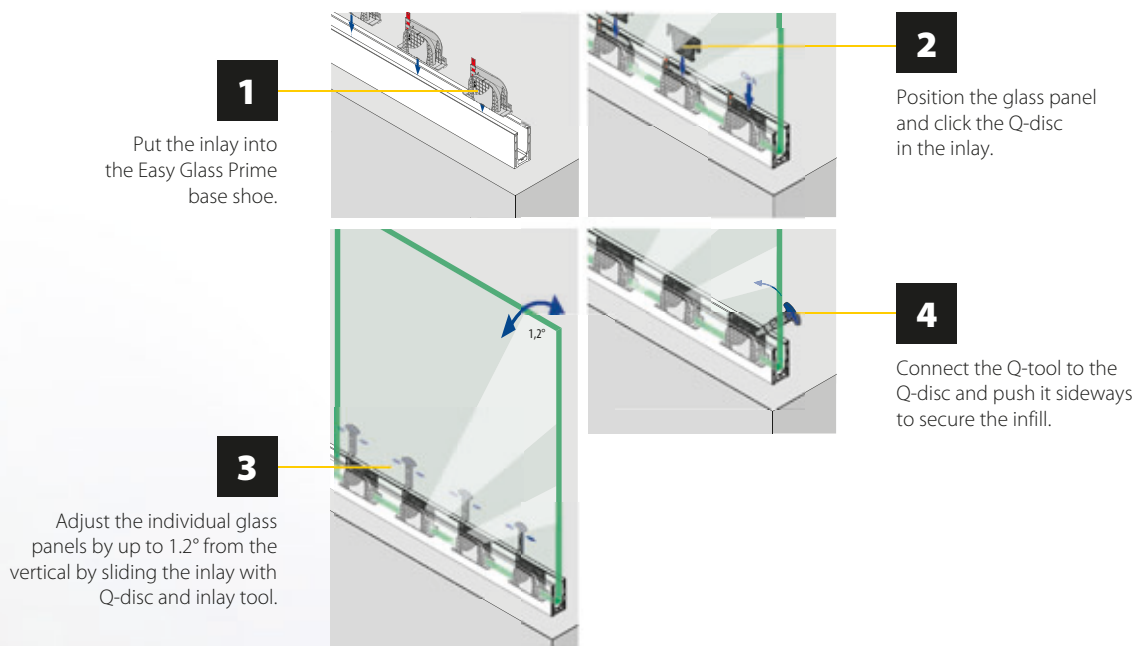

BS 6180 CERTIFIED FOR 0.74 AND 1.5 KN/M

Prime's adjustable Q-disc System comes in two different sets: one containing four inlays and discs, the other containing five.

When to choose four inlays

Install four inlays and discs per metre and you have a balustrade certified to hold linear side forces of up to 0.74 kN/m. Perfect for light to medium use, such as in a private residence or office building.

When to choose five inlays

Go with the five inlay and disc set per metre to create a balustrade certified to hold linear side forces of up to 1.5 kN/m. Ideal for medium to heavy use, such as in shopping centres or residential towers.

Railing bases

EASY GLASS® PRIME - Base shoe, top mount

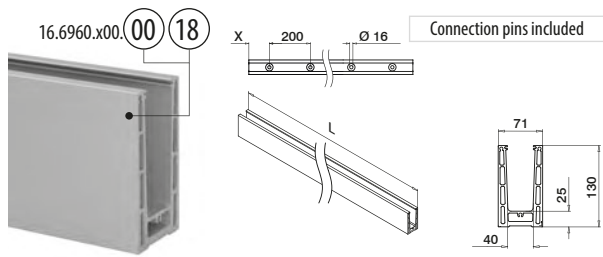

MOD 6960

Aluminium	Mill finish			
INDOOR	X			
16.6960.500.00	100	QS-560 / QS-561	L = 5000 mm	
Aluminium	Brushed aluminium			
OUTDOOR	X			
16.6960.000.18	50	QS-560 / QS-561	L = 2500 mm	
16.6960.500.18	100	QS-560 / QS-561	L = 5000 mm	

NEW

International Design Model Protection

Accessories

EASY GLASS® PRIME - Q-disc and inlay tool



MOD 6922

Accessories	Q	
19.6922.000.00	Q-84	1

NEW

Railing bases

EASY GLASS® PRIME - Adjustable Q-disc System (rubber set, inlay and Q-disc®)

For glass alignment

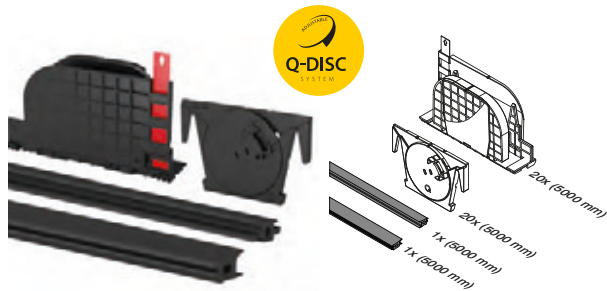

MOD 6960

Accessories	F	T	
19.6960.922.00	0.74 kN	21,52 (10 - 1,52 - 10)	L = 5000 mm
19.6960.822.00	1.5 kN	21,52 (10 - 1,52 - 10)	L = 5000 mm

NEW

International Design Model Protection

Q-disc® System: Glass is securely retained. Drilling is not necessary.

Q-INFO MOD 6960

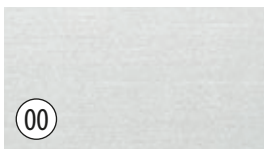

Mill finish aluminium

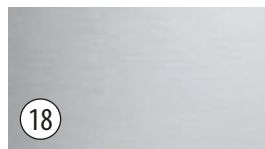

Brushed and anodised aluminium

Q-INFO MOD 6922

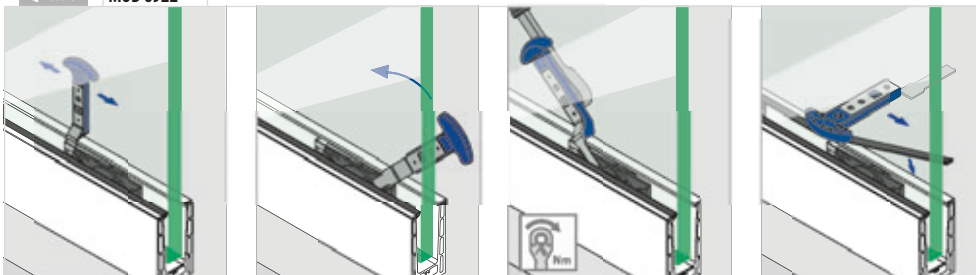

Railing bases

EASY GLASS® PRIME - End caps, top mount

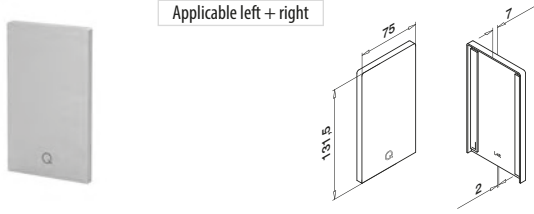

MOD 6734

Aluminium	Mill finish	
INDOOR		
16.6734.060.00		1
Aluminium	Brushed	
OUTDOOR		
16.6734.060.18		1

NEW

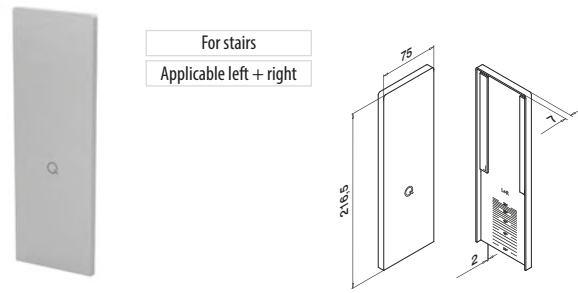

MOD 6736

Aluminium	Brushed	
OUTDOOR		
16.6736.060.18		1

NEW



Railing bases

EASY GLASS® PRIME - Shoe shims

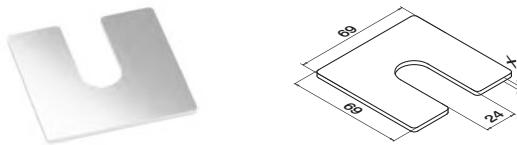

MOD 6921

Aluminium	Mill finish	X	
19.6921.170.00		1	100
19.6921.270.00		2	100
19.6921.370.00		3	100

Railing bases

EASY GLASS® - Connection pin

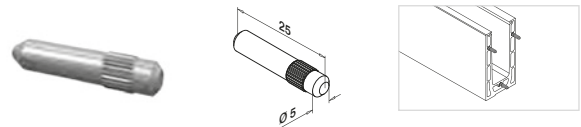

MOD 3005

316		
OUTDOOR		
14.3005.000.00		6



Q-INFO MOD 6734

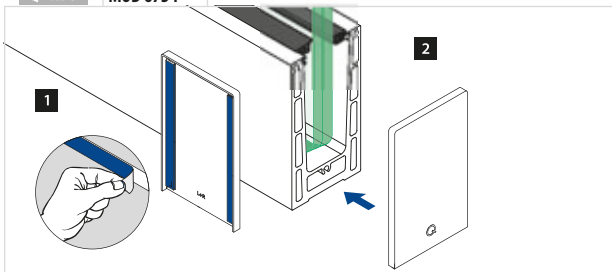

Q-INFO MOD 6736

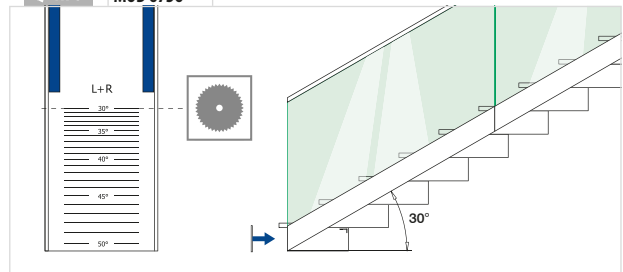

EASY GLASS® PRIME - Connectors, top mount

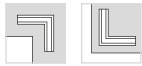

Internal and external corner

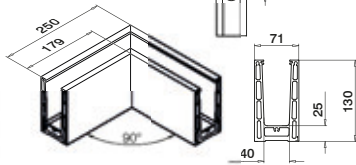

MOD 6313

Aluminium		Mill finish		
INDOOR				
16.6313.060.00	QS-558 / QS-561			1
Aluminium		Brushed		
OUTDOOR				
16.6313.060.18	QS-557 / QS-560			1



Fixing materials for railing systems

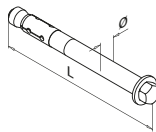

MOD 4712

Zinc-plated							
INDOOR		QS	Type	Ø		L	
19.4712.110.15	QS-561		Q SZ 12/10	12	Ø12	85	25
316							
OUTDOOR		QS	Type	Ø		L	
19.4712.110.14	QS-560		Q SZ 12/10 A4	12	Ø12	85	25

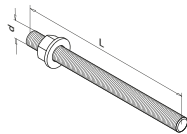

MOD 4412

Zinc-plated							
INDOOR		QS	Type	M		L	
19.4412.175.15	QS-276		Q-VMU-A 12x175	12	14	175	10
316							
OUTDOOR		QS	Type	M		L	
19.4412.175.14	QS-277		Q-VMU-A 12x175	12	14	175	10

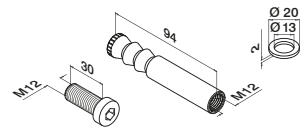

MOD 4512

Zinc-plated					
INDOOR		QS	Type		
19.4512.124.15	QS-558		Q VMZ-IG 90 M12	Ø18	10
316					
OUTDOOR		QS	Type		
19.4512.124.14	QS-557		Q VMZ-IG 90 M12 A4	Ø18	10



EASY GLASS® PRIME - Base shoe, top mount, 0,74 kN

Q-INFO MOD 6960

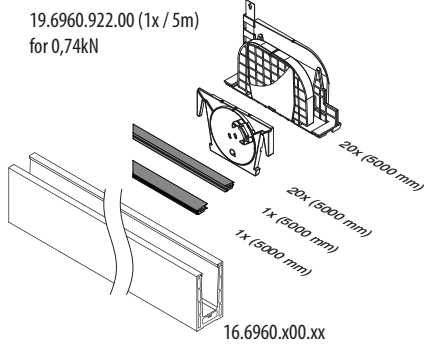
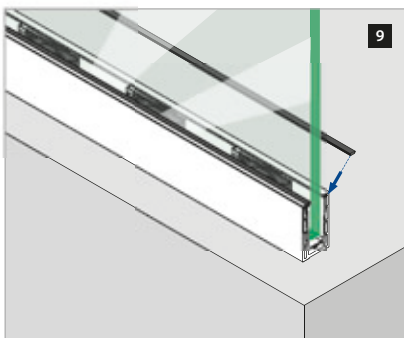
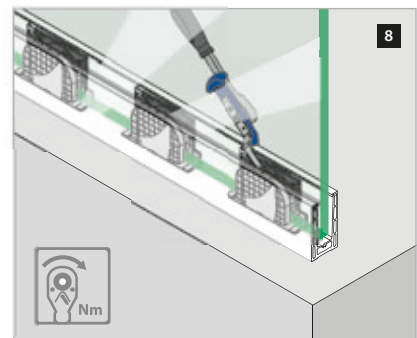
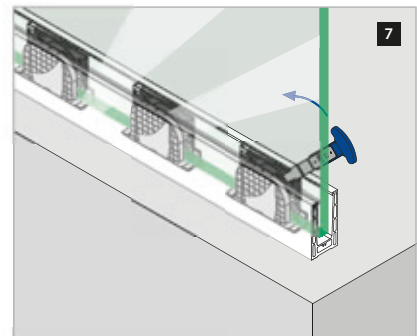
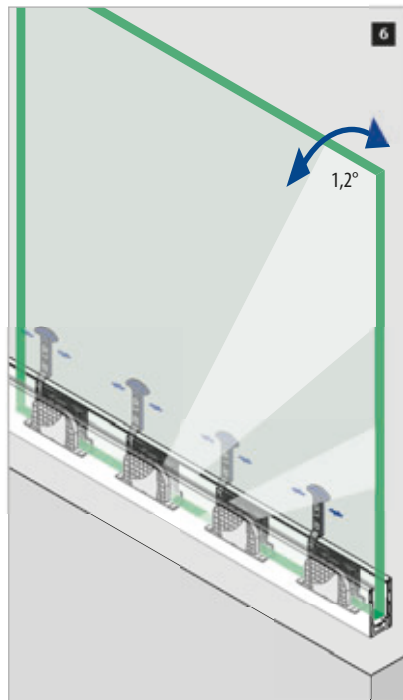
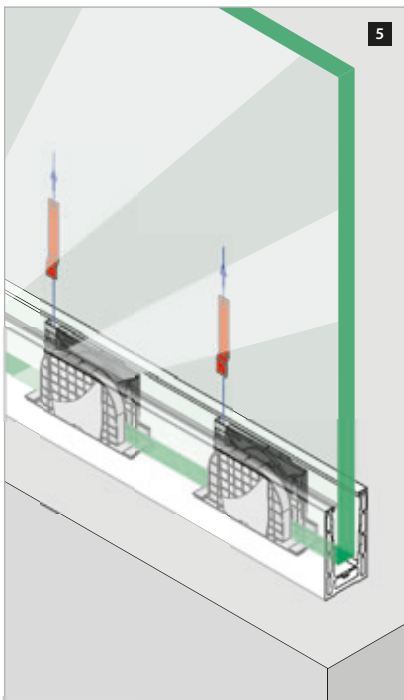
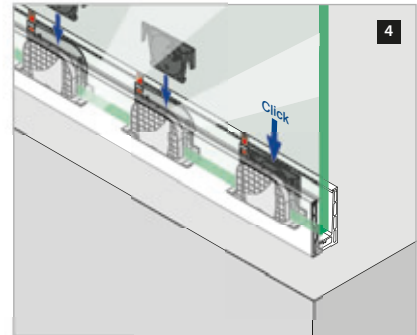
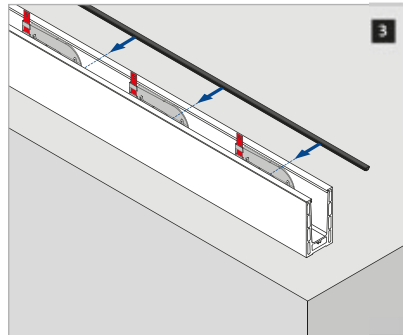
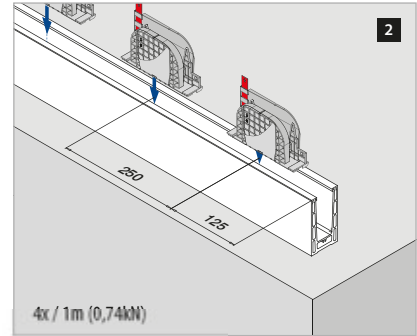
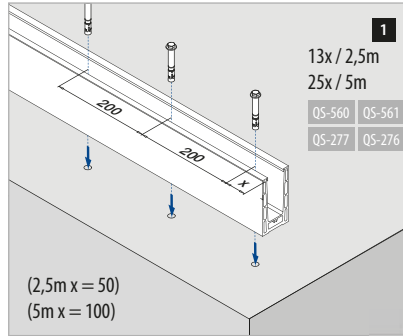
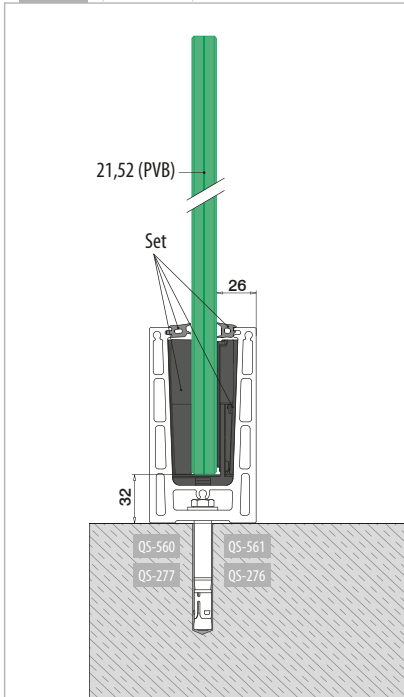

EASY GLASS® PRIME - Base shoe, top mount, 1,5 kN

Q-INFO MOD 6960

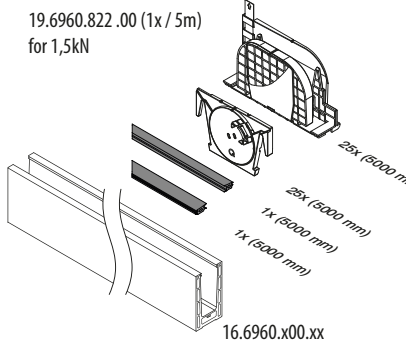
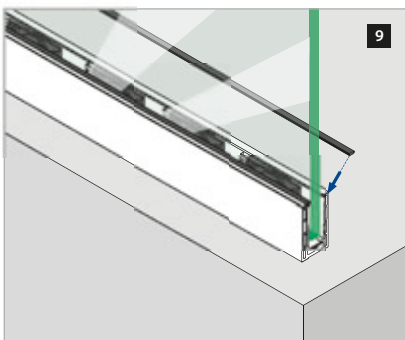
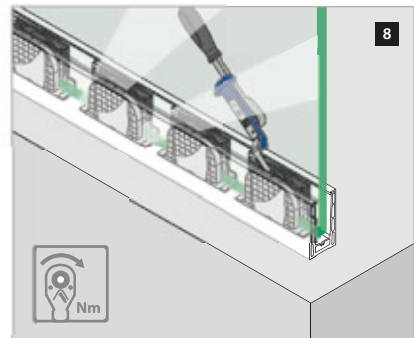
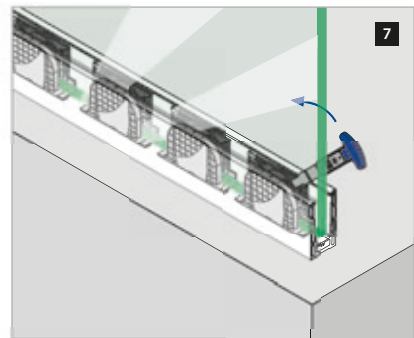
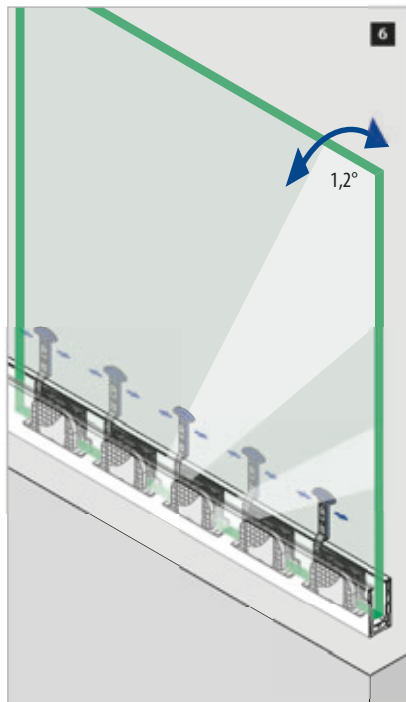
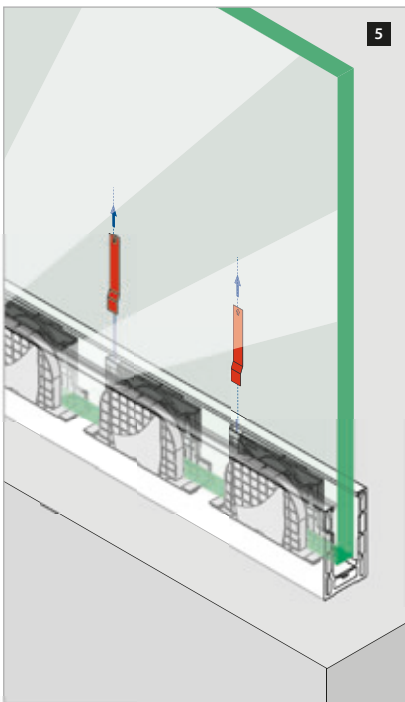
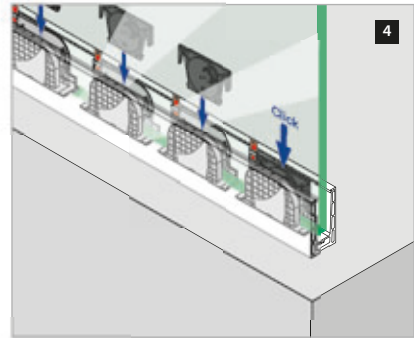
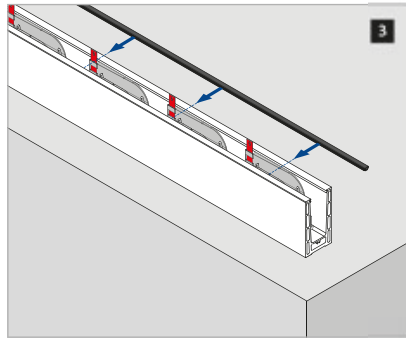
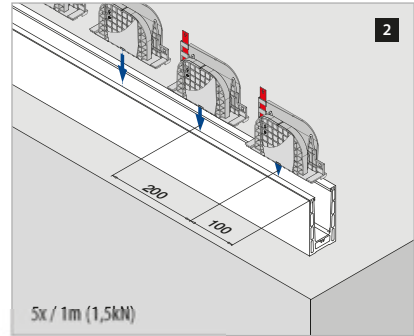
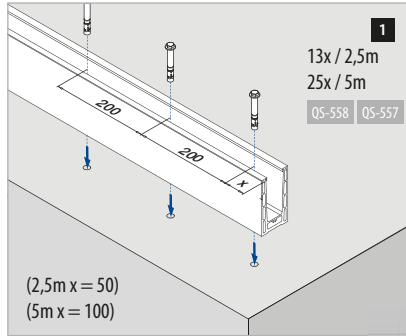
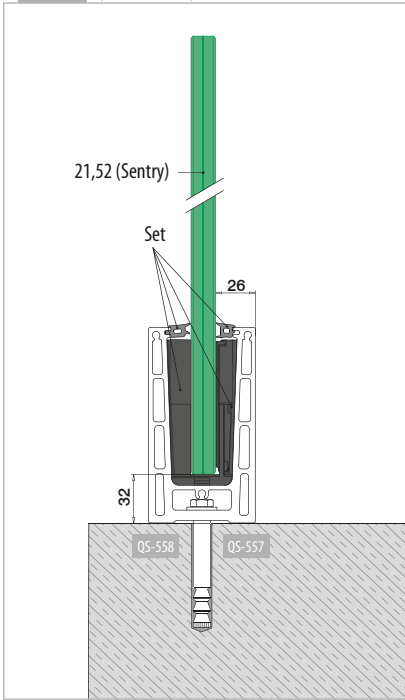



FASTEST ALIGNMENT EVER





EASY GLASS PRIME ORDER NOW

For product specifications, including information about all Easy Glass® Prime components, please call +44 (0) 1782 711 676 or email us at sales.uk@q-railing.com.

Try Prime

Want to try Easy Glass Prime first? Book a visit from the Q-railing roadshow team at your premises and get a personal Easy Glass Prime workshop!

**REQUEST
A FREE
COPY NOW!**



**Curious to find out
about the rest of the
Q-railing range?**

Get your hands on
our 2018/2019 catalogue.



Q-railing

Unit 1, Tunstall Arrow
James Brindley Way
Stoke-on-Trent
Staffordshire, ST6 5GF
United Kingdom

T. 0800 781 42 45 | 01782 711 676
F. 0800 781 42 46
sales.uk@q-railing.com

The prices shown are net, exclusive and valid for Q-railing Europe Holding GmbH Branch UK.
All our product deliveries are subject to our terms and conditions. Misprints reserved.